

CliniMix® CMV2 Wall Mounted Hands Free POU, Proximity Sensor with Temp. Monitoring

PRODUCT CODE:

- 100.41.21.20 – CP Faceplate
- 100.41.21.30 – Glass Faceplate

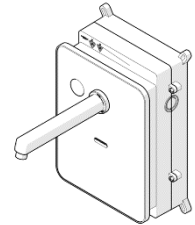

TABLE OF CONTENTS

1.0	INTRODUCTION	2
2.0	SAFETY	2
3.0	DESCRIPTION	2
4.0	DIMENSIONS	2
4.1	TECHNICAL DATA	3
4.2	SENSOR DETAILS	3
5.0	WATER SUPPLY CONDITIONS	3
5.1	INTRODUCTION	3
5.2	SUPPLY PRESSURE REQUIREMENTS	3
6.0	PRE-INSTALLATION	4
7.0	INSTALLATION	5
7.1	OPERATION AND TESTING	8
7.2	SENSOR SETTING INSTRUCTIONS	8
8.0	COMMISSIONING	9
9.0	OPERATION	11
10.0	SERVICING	11
10.1	FREQUENCY OF REGULAR SERVICING	11
10.2	GENERAL SERVICING	12
10.2.1	STRAINER AND NON-RETURN VALVES	12
10.2.2	THERMOSTATIC CARTRIDGE	13
11.0	MAINTENANCE	16
11.1	MIXED WATER TEMPERATURE ADJUSTMENT	16
11.2	REMOVAL AND INSPECTION OF CARTRIDGE	17
11.3	IMPORTANT NOTES ON DEBRIS	18
11.4	MAINTENANCE CLEANING	18
12.0	DISINFECTION	19
13.0	TROUBLESHOOTING	20
14.0	WARRANTY	21

1.0 INTRODUCTION

CliniMix® CMV2 Wall Mounted Hands Free Point Use, Proximity Sensor is a high-performance thermostatic mixing valve suitable for a wide range of applications. The mixing valve has the following features:

- This point of use thermostatic mixer provides state of the art features to comply with healthcare requirements.
- Suitable for high and low water pressure systems.
- Provides high stability of mixed water temperature even under changing inlets conditions.
- Ensures rapid shut down of mixed outlet flow in the event of hot or cold water supply failure.
- Designed for quick and simple in-situ servicing.
- Suitable for installation into AS3500 compliant systems with hot water temperature as low as 55°C.
- Smooth internal components and body reduces scale build-up and bacteria growth.
- Maximum temperature limiter fitted for protection from accidental scalding.
- Clean smooth lines facilitate fast and easy cleaning.
- Complies with the requirements of AS 4032.4 – Thermostatic Mixing Valves.
- Self-draining spout design.
- Unique hygiene flush feature for in-situ disinfection.
- Suitable for connection with CliniMix CMM for continuous outlet temperature monitoring.

2.0 SAFETY

CliniMix® CMV2 Wall Mounted Hands Free Point Use, Proximity Sensor is a high-performance valve designed to give stable and dependable operation, provided it is installed, commissioned, operated and maintained as per the recommendations outlined in this manual. It should be noted however that this valve should not be considered as an alternative to adequate supervision and duty of care during its use and operation.

3.0 DESCRIPTION

This manual covers the CliniMix® CMV2 Wall Mounted Hands Free Point Use, Proximity Sensor mixer. This product is designed to provide water in a safe temperature for washing. This mixing valve is supplied with integral isolating valves, strainers, check valves, flow regulators located in-body and a facility for thermal disinfection of the cold inlet side and mixed water outlet.

Avoid using heat for soldering near the mixer inlets to prevent damage to internal components.

4.0 DIMENSIONS

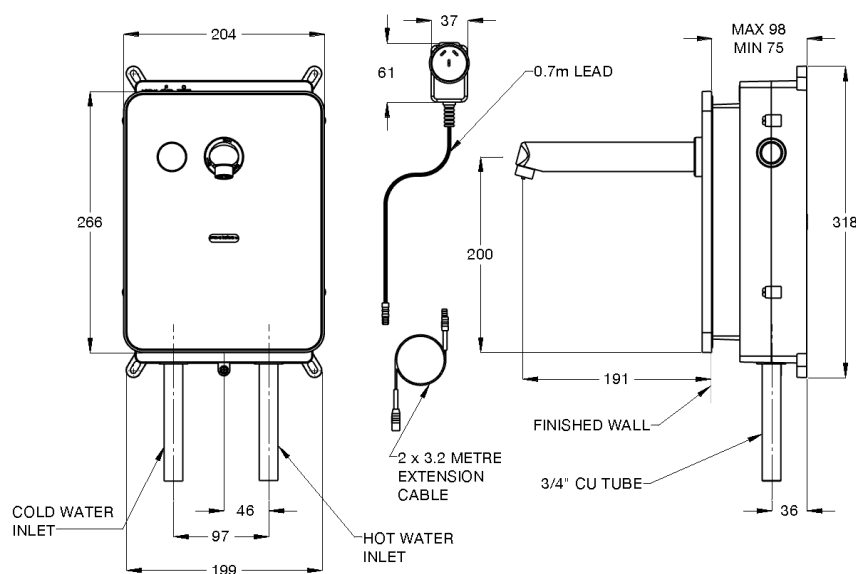

4.1 TECHNICAL DATA	
Inlet	3/4" Cu Tube
Outlet	Flow Straightener
Headwork	Thermostatic mixing valve Solenoid
Mains Powered (Transformer)	90 – 264V - 47/63Hz 0.15A
	6.75V DC – 0.5A
	0.7m
Finish	Chrome

NOTE: Galvin Specialised continually strive to improve their products. Specifications may change without notice.

Table 1. Technical information

4.2 SENSOR DETAILS	
Input Voltage	6.75V DC – 0.5A
Sensor function	Proximity
Pre-set line purge feature interval:	72 hours after last flush, water flow duration 60 sec
Pre-set continuous run:	10 min

5.0 WATER SUPPLY CONDITIONS

5.1 INTRODUCTION

This thermostatic mixer with proximity sensor is manufactured to the highest standards and has approval to AS4032.4 which permits it to be installed in healthcare establishments such as hospitals, nursing homes and residential care homes. When installed in healthcare establishments the supply conditions detailed in Table 2 must be observed and the commissioning and servicing requirements detailed on section 8.0 & 10.0 must be followed.

5.2 SUPPLY PRESSURE REQUIREMENTS

This mixer is designed to be installed on all types of plumbing systems. Hot and cold water supply pressures should be reasonably balanced; however, the mixer will function within specification on unequal pressures up to 10:1. The mixer has integral isolating valves which permit servicing of the strainer, check valve/flow regulator and thermostatic cartridge. They are also used for thermal disinfection. The minimum pressure for the correct thermal operation is 30kPa. However, to achieve an acceptable flow performance at very low pressures it may be necessary to remove the combined check valve and flow regulators and replace them with simple check valves to facilitate thermal disinfection.

Working Temperature Range (°C)	Min	5
	Max	80
Minimum Temperature Differential (between the supply and the outlet temperature) (°C)	Min	10
Adjustable Temperature Range (°C)	Min	35
	Max	45
Working Pressure Range (kPa)	Min	30
	Max	500
Permitted Supply Pressure Variation	10:1	
Factory Set Thermostatic Temperature (°C)	41	
Maximum Thermostatic Temperature (°C)	45	
Nominal Flowrate (LPM)	8	

Table 2. Water supply conditions

Note: Tapware must be installed in accordance with the provisions of AS/NZS 3500. Installations not complying with AS/NZS 3500 may void the product and performance warranty provisions.

6.0 PRE-INSTALLATION

MOUNTING DETAILS – WALL PREPARATION

1. Cut out hole in wall as per dimensions shown below. The depth of the hole must be between 75 and 95mm from the finished wall face.
2. Drill four holes located as per picture below using drill diameter suitable for mounting system (not supplied) that will be used for the box installation.

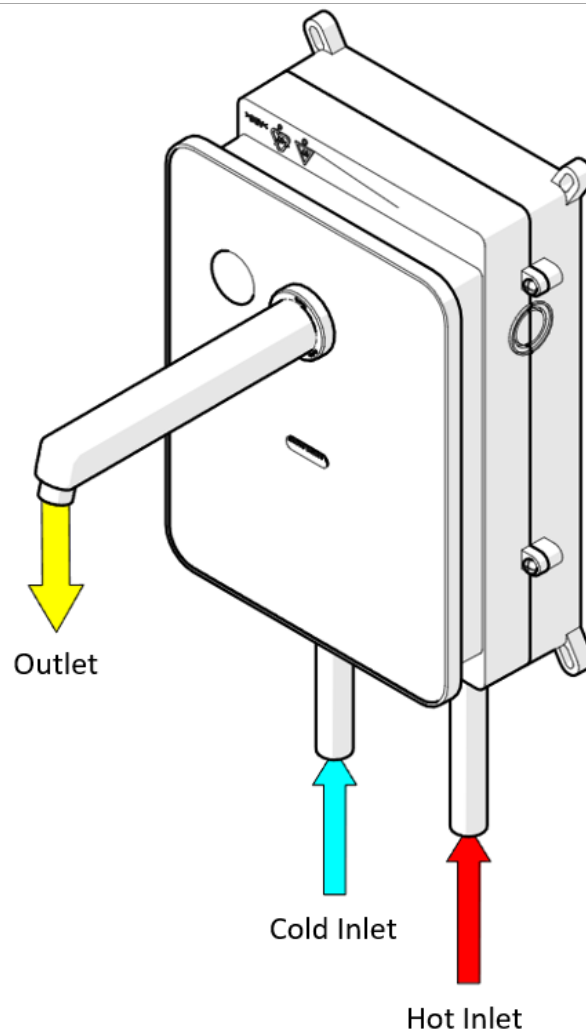
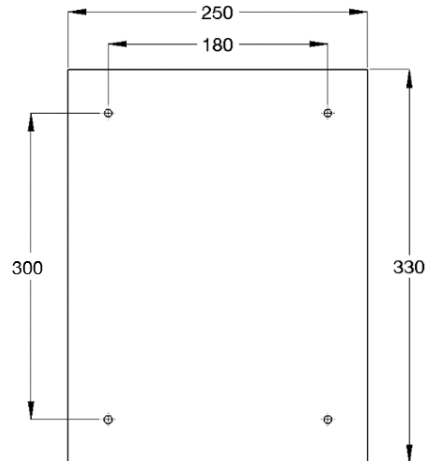

7.0 INSTALLATION

The CliniMix® CMV2 Wall Mounted Hands Free Point Use mixing valves must be installed using the appropriate Standard, Code of Practice and legislation applicable to point of install.

The CliniMix® CMV2 Wall Mounted Hands Free Point Use mixing valves must be installed by a licensed plumber. If the valve is not installed correctly then it will not function correctly and may put the user in danger. It may also void the warranty of the valve.

Prior to the installation of the valve, the system must be checked to ensure that the system operating conditions fall within the recommended operating range of the CliniMix® CMV2 Wall Mounted Hands Free Point Use mixing valve. If the hot water supply temperature is greater than 80° Celsius, the valve may be damaged. If the temperature of the hot water will rise above 80° Celsius a suitable temperature limiting valve must be fitted to the hot water supply, prior to the inlet fittings. This temperature limiting valve must be installed as per the manufacturer's instructions. It is important that both inlets dynamic supply pressures are 500kPa or less. If either supply pressure exceeds 500kPa then a suitable pressure reducing valve must be fitted prior to the inlet control valve to reduce the pressure to an acceptable limit.

These pressure reducing valves must be installed as per the manufacturer's instructions. To achieve optimum performance from the valve it is recommended that the inlet pressures are balanced to within 10% of each other.

To ensure that the mixing valve operates correctly, it is necessary that the pipework is thoroughly flushed with clean water before the valve is installed. This will remove any physical contaminants from the pipework, ensuring trouble-free operation. During the flushing procedure, care should be taken to prevent water damage occurring to the surrounding area.

The valve should be installed so it can be easily accessed for maintenance or servicing.

During installation or servicing, heat must not be applied near the mixing valve or inlet fittings, as this will damage the valve and inlet fittings internals. Failure to comply with this requirement will damage the valve and fittings. It will put the user at risk, and it will void the warranty of the valve.

Note: To effectively control microbial hazards during system design, installation, commissioning and maintenance, the requirements of local legislation shall be adhered to.

Note: In some installations, certain types of tapware devices such as flick mixers and solenoid valves are used. The water pressure may be seen to spike outside that recommended for the valve, during rapid shut off conditions with these types of devices. Even if the spike only lasts a split second it is still considered to be outside the operating conditions and may cause the valve to operate incorrectly. In the event that this does occur, measures must be taken to control the spike, such as the installation of an inline pressure reducing valve directly before the valve inlets.

IMPORTANT: Galvin Specialised products must be installed in accordance with these installation instructions and in accordance with AS/NZS 3500, the PCA and your local regulatory requirements. Water and/or electrical supply conditions must also comply to the applicable national and/or state standards. Failing to comply with these provisions shall void the product warranty and may affect the performance of the product.

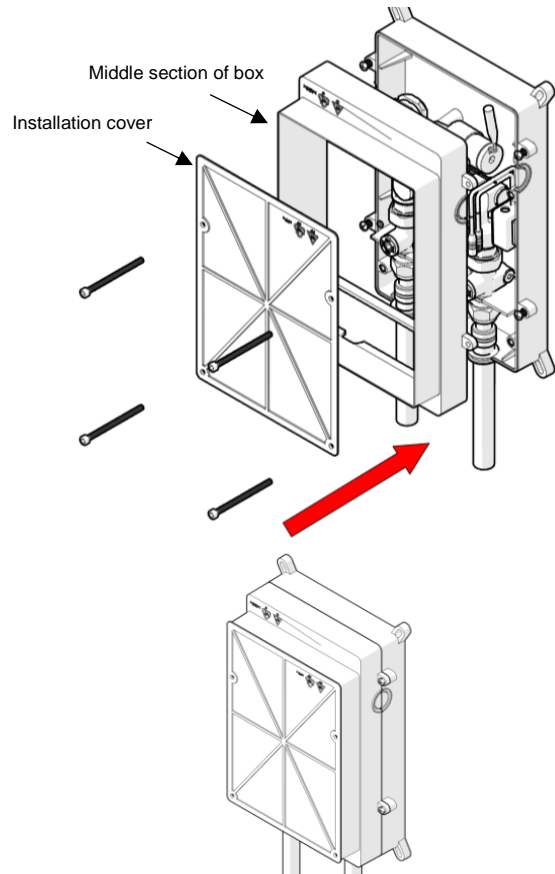
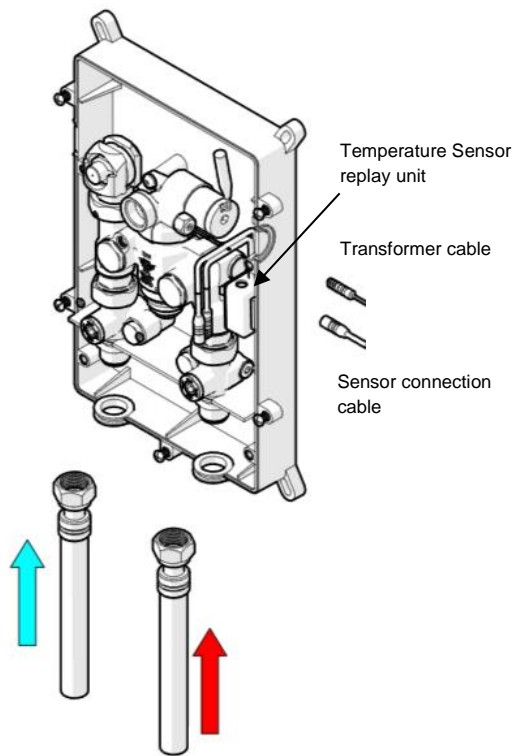

1. Fit box and connect with mains

- Create an opening on the left or right side of the box. Push the transformer cable through the supplied grommet and leave around 150mm of free cable inside the box.
- Using suitable fittings, attach the box inside the wall. Box must be leveled and installed parallel to the finished wall.
- Connect supplied inlets to the thermostatic mixer and then with mains. Attach the middle section of the box.
- Attach one part of the supplied 3M Dual Lock fastener on the relay unit, and the other one in the most convenient spot of the box. Recommended position shown on the picture above. Align both sides of the fastener and press the relay unit to fix it on the box.
- Check if the isolating valves are in the 'CLOSE' position.

2. Preparation for wall finishing

- Fix installation cover to protect the mixer against dust.
- Leave cover attached until wall is finished.



Note: Avoid using heat for soldering near the mixer box and inlets.

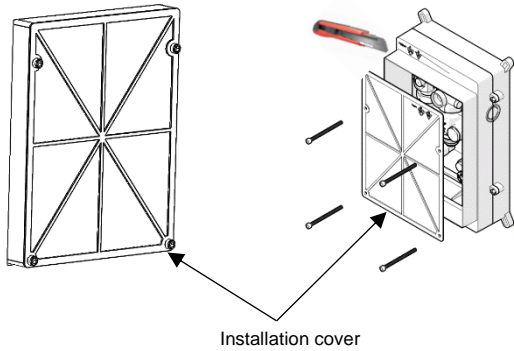

3. Trimming box

- When the finished wall is ready, detach the installation cover. Retain the screws.
- Cut off the protruding part of the box.

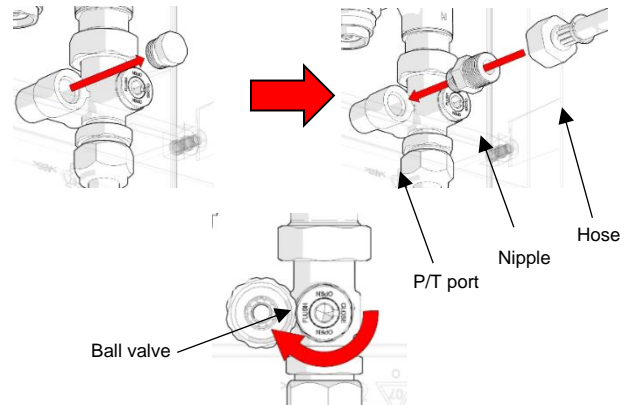

4. Flush the pipework

- Attach flushing kit (not supplied) to P/T port.
- Direct the hose into basin. Slowly change the ball valve position to 'FLUSH'.
- When all pipework is correctly flushed turn the ball valves back to 'CLOSE' position, detach flushing kit and plug back the P/T port.

Note: A flushing kit is available. For more information, please visit www.galvinengineering.com.au.

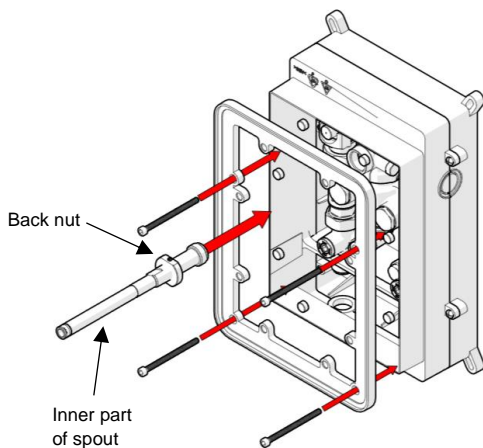

5. Attach frame

- Attach frame using the screws removed from the installation cover.
- Screw in the inner part of the spout to the mixing valve body until it stops. Tighten to a torque of 10Nm.
- Align the position of the back nut with the faceplate recess in frame and secure using grub screw. The back nut must support the back of the faceplate when installed.

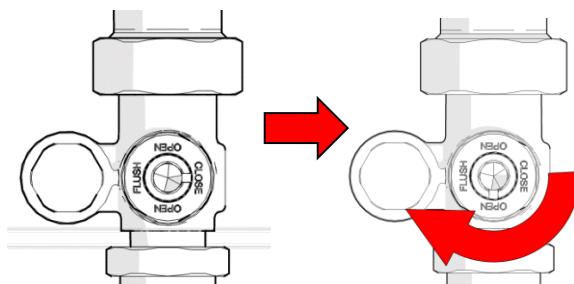

6. Sensor activation.

- Check if the ball valves are in the 'CLOSE' position.
- Connect the temperature relay cable and solenoid cable to the sensor, temperature monitoring cable with temperature relay cable and then the sensor with transformer.
- Activate the 'Temporary off' function (see section 7.2 Sensor Setting Instructions).
- Slowly turn the inlets ball valves to 'Open' position.

Note: There are two male connectors in the controller. The solenoid can be connected to any of them.

Note: If flow appear from the outlet the 'Temporary off' function hasn't been activated. Activate the function again.

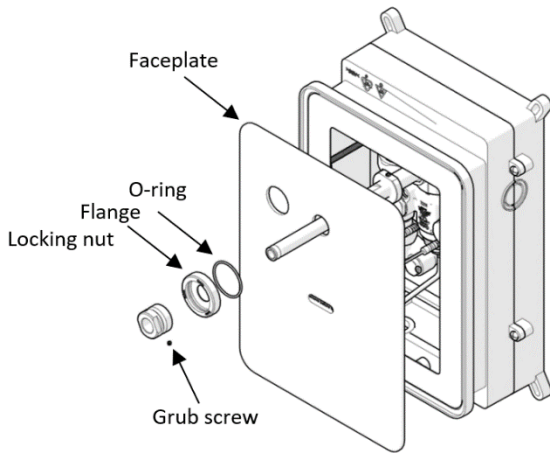

7. Fit the faceplate

- Fit the faceplate in position, it will be held in place by a set of magnets.
- Ensure the backnut is supporting the faceplate.
- Insert the flange and screw in the locking nut.
- Lock the locking nut using grub screw.

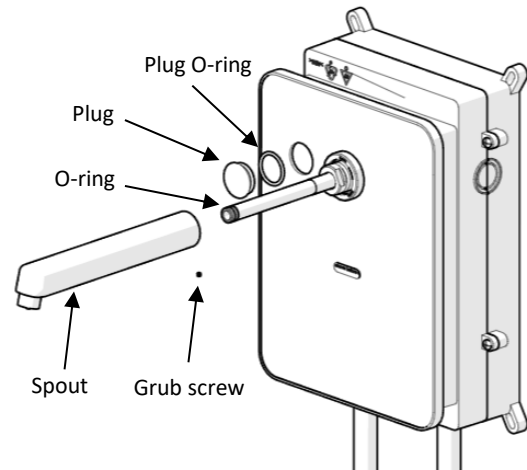

8. Install Spout and plug

- Ensure there are two O-rings on the inner part of the spout before installing the outer spout.
- Push spout to the end and lock with grub screw to secure.
- Ensure the disinfecton key cover is fitted to the open hole as shown.

7.1 OPERATION AND TESTING

After installation, check for leaks and correct operation.

Hand Movement activates the mechanism and delivers the water with the pre-set temperature.

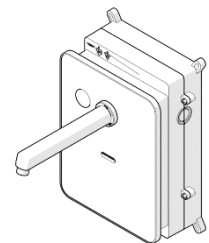

7.2 SENSOR SETTING INSTRUCTIONS

Signs and symbols	🎯	Touch function		✋	Hand/object within sensor area
	💧💧💧	Water flows		1	LED flashes Green
	XXX	Water flow stops	2	LED flashes Red	
	H – hours / min. – minutes / sec. - seconds				

FUNCTION	PROCEDURE	FEEDBACK SIGNAL	INFORMATION	DEFAULT	SETTING RANGE Via IQUA Touch
First startup After installation	1x app. 4 sec. till		Remove hand/object from sensor area	-	-
	wait	+	2x/sec., keep out of sensor area		
	wait till	1x	Confirmation, ready for operation		
Temporary off «Cleaning mode» Activate	1x app. 2 sec. till	1x	Extended function mode is active	2 min.	
	2x a app. 0.5 sec		Pulsing during active function		
Temporary off Stop	1x app. 2 sec.	1x	Manual stop		
	or automatic	1x	Automatic after preset time		
Continuous run Activate	1x app. 2 sec. till	1x	Extended function mode is active	5 min.	0.5-20 min. (in 0.5 steps) min.
	1x minimum 3 sec. (max. 5 sec.)		Water flows after releasing		
Continuous run Stop	1x app. 2 sec.		Manual stop		
	or automatic		Automatic after preset time		
line purge feature activate / deactivate << Automatic flush on set interval>> (time of waterflow: 3 min)	1x app. 2 sec. till	1x	extended function mode is active	12h	Off 12 h 24 h 48 h
	1x app. 25 sec. till	1x - 4x	1x= off, 2x=12h, 3x= 24h, 4x= 48h ignore flashes after 5 sec. and 10 sec. – keep touched till 1x - 4x after app. 25 sec., releasing defines interval		
	Wait till	1x	Confirmation, ready for operation		
restart electronics	1x app. 2 sec. till	1x	extended function mode is active		
	2x a app. 0,5 sec		pulsing during active function		
	1x app. 5 sec. till	4x	1x/sec.		
	Release and wait till	+	1x/sec., keep out of sensor area		
	Wait till	1x	confirmation, ready for operation		

8.0 COMMISSIONING

Initial Test for Correct Operation

The following must be checked to ensure the correct performance of the progressive thermostatic mixer:

- the supply pressures and temperatures are within the range of operating pressures and temperatures for the thermostatic valve.
- the supply temperatures are within the range permitted for the unit.

Please record the testing done during the commissioning and record the temperature of the hot and cold-water supplies and the temperature of the mixed water at the full hot setting.

A calibrated digital thermometer having rapid response time with maximum temperature hold will be required to check and set the outlet mixed temperature of the mixer.

To Commission

To test the temperature, open the valve and allow the mixed heated water to flow for at least 30 to 60 seconds so the temperature can stabilise before taking a temperature reading at the outlet with a digital thermometer. The flow rate should be at least 4L/min.

The temperature should be taken close to the mixer's outlet and if the outlet temperature requires adjustment, then follow the temperature adjustment in the installation instructions.

Shut Down Test

Once the correct outlet temperature has been achieved, the valve's internal mechanism should be exercised at least 3 times by alternately shutting off the hot and cold supplies while the mixer is set in the full hot position.

Shut Down Test 1

With the mixer still on and with both supplies turned on, allow the mixed water temperature to stabilise for at least 15 seconds and note the outlet temperature. While holding a digital thermometer in the outlet flow, quickly isolate the cold water supply to the valve.

The outlet flow should quickly reduce to be less than 0.1L/min following the isolation. Recording of the temperature should continue after isolation and should not exceed the maximum temperature set out in the applicable standard or code of practice for each state.

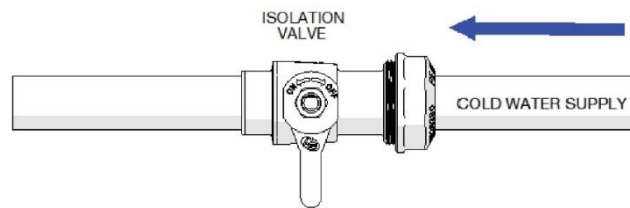

Restore the cold-water supply to the valve. After the mixed water temperature has stabilised, note the outlet temperature ensuring the outlet temperature has re-established. The time taken to stabilise the temperature should not exceed the maximum time set out in the applicable standard or code of practice for each state.

Shut Down Test 2

With the mixer still on and with both supplies turned on, allow the flow to stabilise for at least 15 seconds and record the temperature. Quickly isolate the hot water supply to the valve.

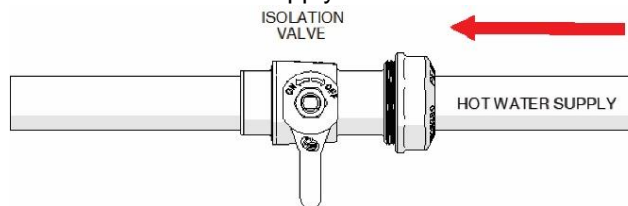

The outlet flow should quickly reduce to be less than 0.4L/min following the isolation. The volume of mixed water discharged for a period of between 5-35 seconds should be measured and should not exceed the maximum volume set out in the applicable standard or code of practice for each state.

Restore the hot water supply to the valve and measure and record the outlet temperature after the mixed water temperature has stabilised. The time taken to stabilise the temperature should not exceed the maximum time set out in the applicable standard or code of practice for each state.

Ensure that all details of the Commissioning Report are completed, and a copy is kept with the installer and owner of the premises.

The valve is now commissioned, and it can be used within the technical limits of operation.

NOTE: In some installations, certain types of tapware devices such as flick mixers and solenoid valves are used. The water pressure may be seen to spike outside that recommended for the valve, during rapid shut off conditions with these types of devices. Even if the spike only lasts a split second it is still considered to be outside the operating conditions and may cause the valve to operate incorrectly. In the event that this does occur, measures must be taken to control the spike, such as the installation of an inline pressure reducing valve directly before the valve inlets.

To ensure that the mixing valve operates correctly, it is necessary that the pipe-work is thoroughly flushed with clean water before the valve is installed. This will remove any physical contaminants from the pipe-work, ensuring trouble-free operation. During the flushing procedure, care should be taken to prevent water damage occurring to the surrounding area.

It is a requirement of AS3500.4. that “Each thermostatic mixing valve shall have an isolating stop tap/valve, line strainer and non-return valve fitted to the hot and cold water supply lines”. The inlet fittings supplied with each TMV will ensure this requirement is met. If the CliniMix® Thermostatic Mixing Valve is to be installed without the supplied inlet control valves then it will be necessary to install a separate isolating valve, non-return valve and strainer to both inlets to the valve.

Strainers must be fitted to prevent any particulate contamination from entering the valve. These strainers should be 60 mesh stainless steel (0.250mm). Isolating valves are required so that the water supply to the valve can be isolated when servicing is required. Non-return devices must also be fitted to both the hot and cold inlets to prevent cross-contamination.

Ensure that the test plugs in the top of the inlet fittings are tight.

The valve should be installed so it can be easily accessed for maintenance or servicing.

During installation or servicing, heat must not be applied near the mixing valve or inlet fittings, as this will damage the valve and inlet fittings internals. Failure to comply with this requirement will damage the valve and fittings. It will put the user at risk and it will void the warranty of the valve.

Note: The CliniMix® Thermostatic Mixing Valve is intended mainly for use in applications with set temperatures below 45° Celsius. When installed at higher set temperature, the performance may be less than specified in AS4032.4. In such situations consideration should be given to the question of whether an alternative device, i.e. a tempering valve approved to AS4032.2 would provide a greater margin for safety in reducing scalding accidents.

9.0 OPERATION

The proximity sensor starts the water flow when recognises hands presence.

The delivered water temperature is factory set to approximately 41°C.

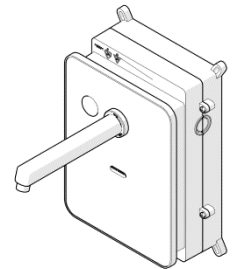

10.0 SERVICING

The need for servicing is normally identified as a result of the regular performance testing.

Application	Maximum mixed water temperature during normal operation	Permitted maximum temperature rise recorded during site testing
Washbasin	41°C	45°C

Table 3. A guide to maximum temperature sets. Please refer to AS3500 for temperature settings

10.1 FREQUENCY OF REGULAR SERVICING

The purpose of servicing regularly is to monitor any changes in performance due to changes in either the system or the product. This may highlight the need to adjust either the supply system or the product. These products should be checked at 6 to 8 weeks and again at 12 to 15 weeks after commissioning. The results are to be compared against original commissioning settings.

If there are no significant changes at the mixed temperature outlet then a 6 monthly servicing cycle may be adopted. Otherwise, servicing checks should be carried out more frequently (e.g. every 4 months).

Follow the recommended maintenance procedures detailed in Section 11.0 Maintenance.

During servicing, note the following:

1. Repeat the procedure of recording and checking supply temperatures. (The same type of measuring equipment should be used).
2. If the temperature has changed significantly from the previously recorded valves, the following should be checked:
 - a. All in-line or integral valve filters are clear of obstruction.
 - b. All in-line or integral check valves are clean and working properly to prevent backflow.
 - c. Any isolating valves are fully open.
 - d. The thermostat is free of debris.
3. When satisfied with the mixed outlet temperatures re-record the temperatures.

10.2 GENERAL SERVICING

General Servicing of the CliniMix® CMV2 Wall Mounted Hands Free Point Of Use Thermostatic Mixers

10.2.1 STRAINER AND NON-RETURN VALVES

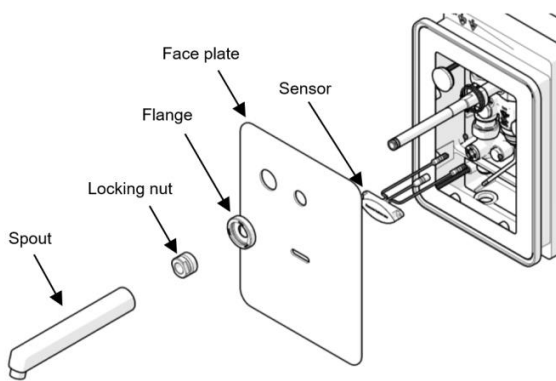

1. Activate the 'Temporary off' function for the sensor (See section 7.2 Sensor Setting Instructions). Disassemble spout and faceplate (reverse steps 7 and 8 in section 7.0 Installation). Disconnect the sensors cables.

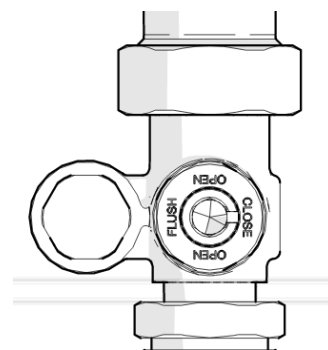

2. Turn the isolating ball valves to the 'CLOSE' position.

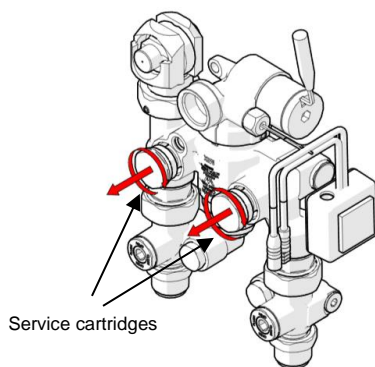

3. Unscrew and remove service cartridges using metric spanner 22mm. Remove non-return valves.

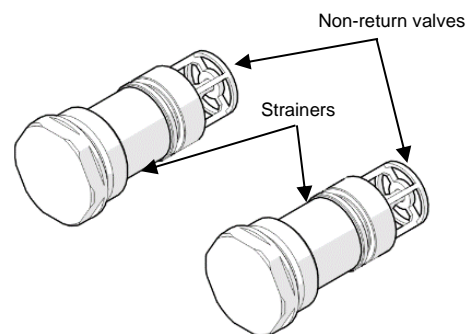

4. The strainers and non-return valves should be cleaned with a dilute water solution of suitable de-scaling solvent (such as CLR), checked for physical damage, and then thoroughly rinsed with clean water. Replace the service cartridges if damaged or faulty non-return valves.

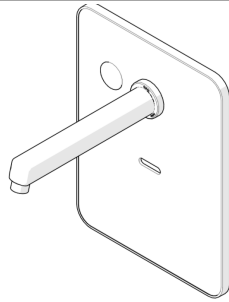

5. Re-fit service cartridges and then reassemble faceplate and spout (See section 7.0 Installation steps 6 to 8).

10.2.2 THERMOSTATIC CARTRIDGE

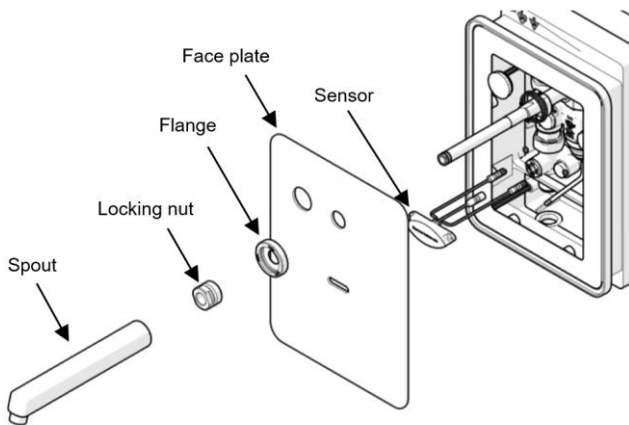

1. Disassemble spout and faceplate (refer to 10.2.1 Strainer And Non-Return Valves step 1).

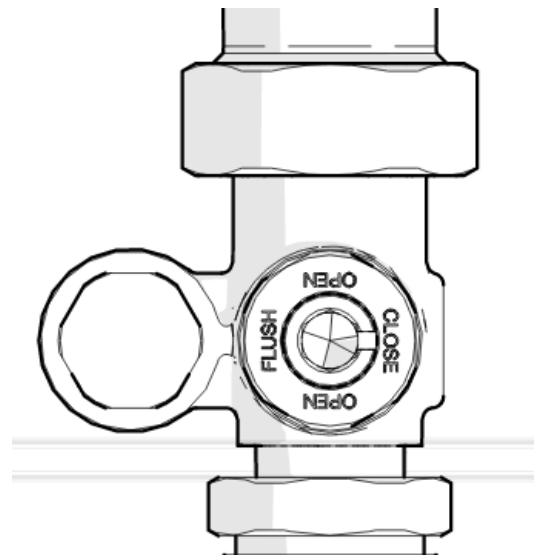

2. Turn the isolating ball valves to 'CLOSE' position.

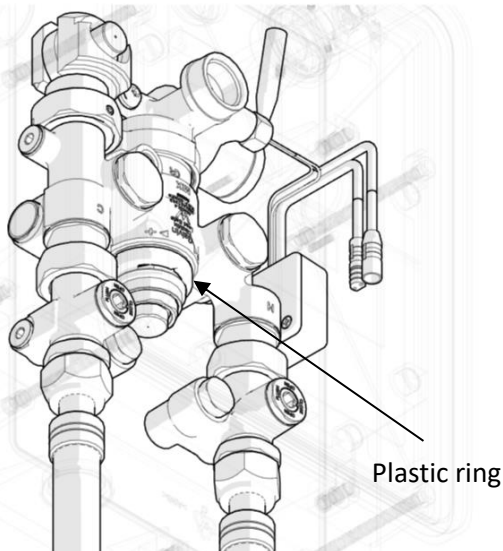

3. Break/remove the plastic lock in the center of the thermostatic mixing valve.

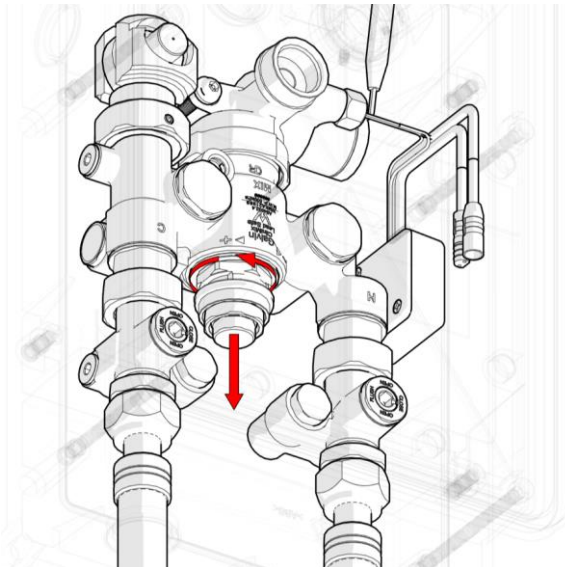

4. Use spanner size 28mm and turn the cartridge in the counterclockwise fashion until it reached the end of its threads. Pull the thermostatic cartridge out of the mixer body.

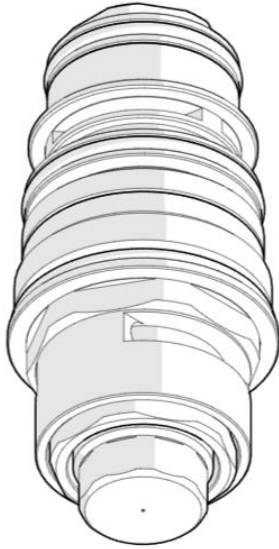

- Remove the cartridge by hand and clean all components thoroughly. Inspect components for damage. If components are damaged, the cartridge must be replaced.

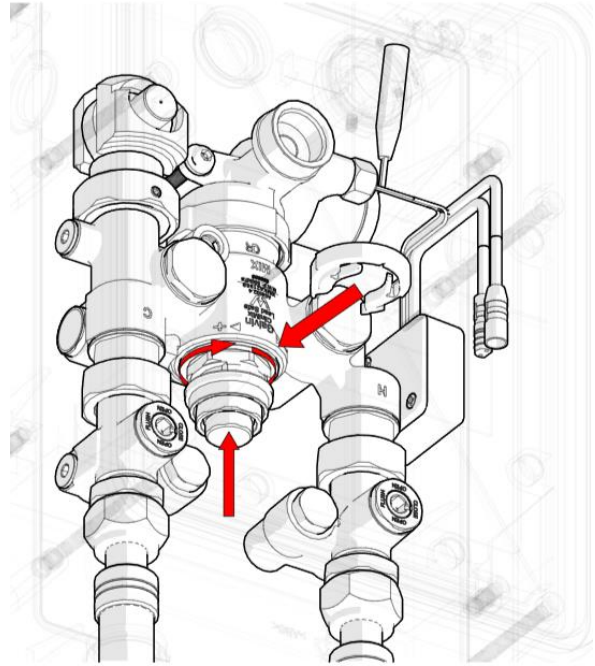

- Cleaned cartridge (or a new cartridge, if this is required) can now be re-installed, by screwing into the mixer body until it reaches a firm stop and tightened. The cartridge should be tightened to a torque of 15Nm. Re-install or install new plastic lock.

Note: Plastic locks are available. For more information, please visit www.galvinengineering.com.au.

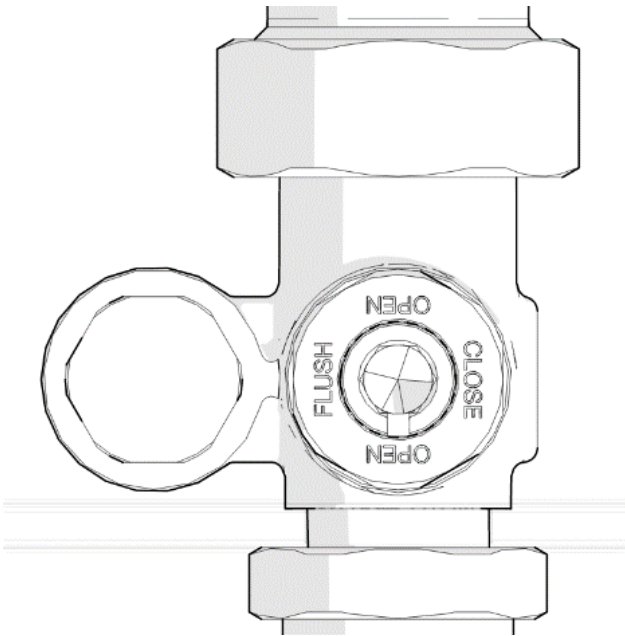

- When service is complete, slowly turn the cold-water isolation ball valve to 'OPEN' position and inspect mixer body for leaks. Repeat with hot water isolation ball valve.

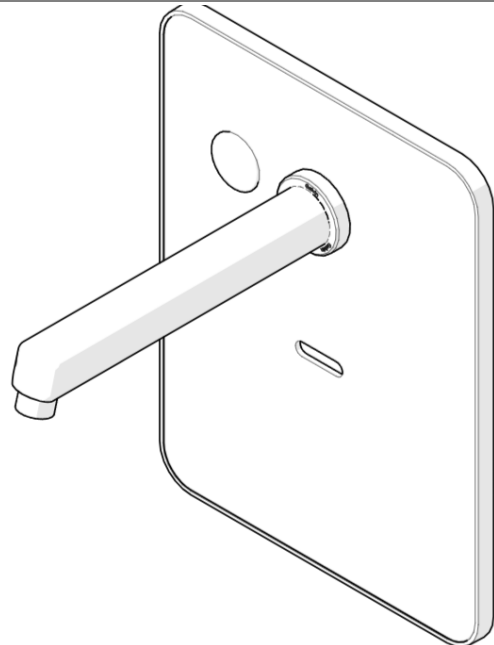

- Re-commission the mixer as per commissioning procedure (see section 8.0 Commissioning).

Annual Maintenance Procedure

- Every 12 months the thermostatic mixer must be inspected & tested. The valve should be inspected for leaks or water damage and appropriate action taken if required.
- Carry out the general servicing of the valve as set out in this document
- A thermal shut down test is performed (Shut Down Test 1 and 2 as set out in this document), and the temperature is reset as required.
- If the valve fails to shut down or fails to maintain its set temperature, then refer to Troubleshooting section.

5 Year Maintenance Procedure

- Every five years the thermostatic mixer needs to have a full service carried out. This service consists of the same procedure as the 'Annual Maintenance Procedure' listed plus the thermostatic mixer cartridge must be replaced.
- After replacing the thermostatic mixer cartridge, a thermal shut down test is performed, and the temperature re-set as required. If the valve fails to shut down or fails to maintain its set temperature, then refer to the troubleshooting section.
- Once the 5 yearly maintenance procedure is complete, the thermostatic mixer should then be commissioned as per instructions.

11.0 MAINTENANCE

When installed as an AS/NZS 4032.4 application it is a requirement that the Commissioning (Section 8.0 Commissioning) and maintenance procedures (Section 11.0 Maintenance) are carried out before use.

11.1 MIXED WATER TEMPERATURE ADJUSTMENT

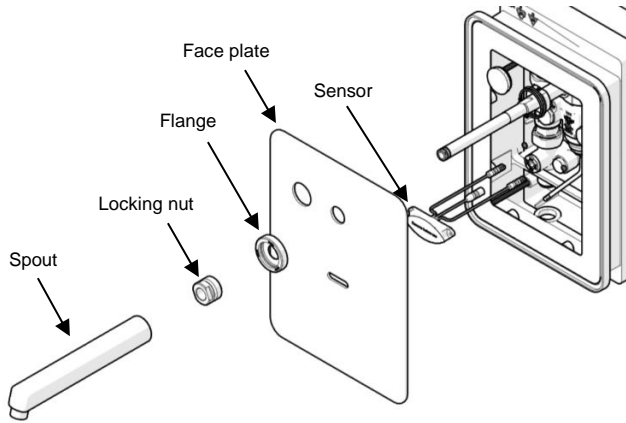

1. Activate the 'Temporary off' function. Disassemble spout, locking nut, flange and faceplate. **Do not** disconnect the sensors cables.

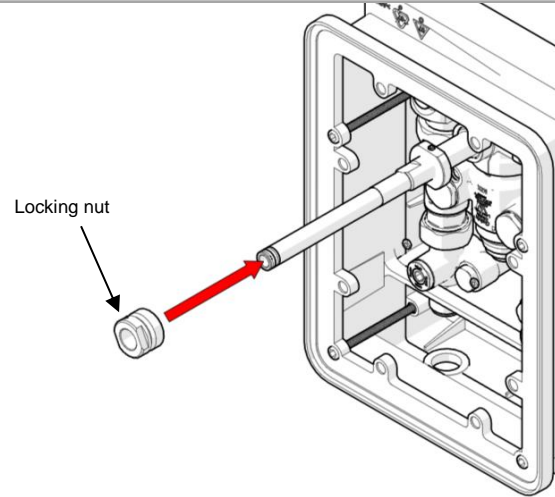

2. Screw back the locking nut, without the faceplate.

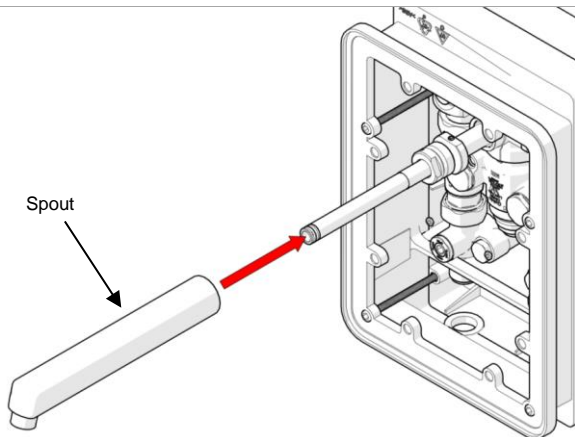

3. Insert spout (without faceplate and flange) and secure.

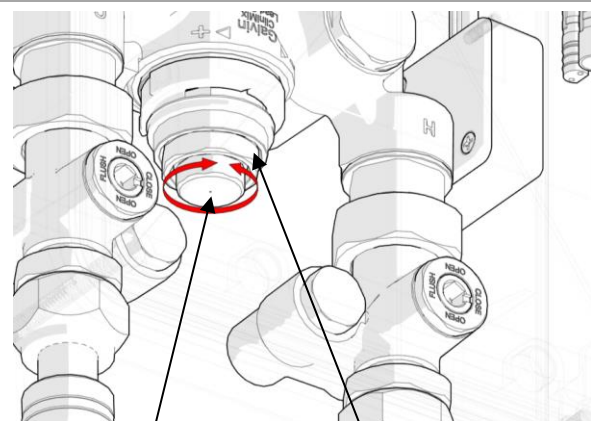

4. Using wrench size 23mm untight the tightening ring. Activate the 'Continuous run' function and using wrench 16mm adjust the temperature by turning the adjustment rod in direction marked on the body. When the mixing temperature is set, holding the adjustment rod tight the tightening ring to prevent changing the adjustment. Stop the 'Continues run' function.

Note: Turning the setting screw clockwise will decreasing the mixed water temperature and turning it counterclockwise will increasing the mixed water temperature (see marking on the body).

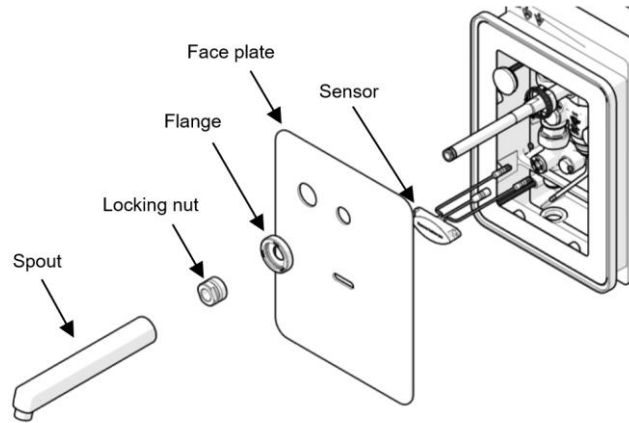

5. Activate the “Temporary Off” function and reassemble the faceplate and spout.

11.2 REMOVAL AND INSPECTION OF CARTRIDGE

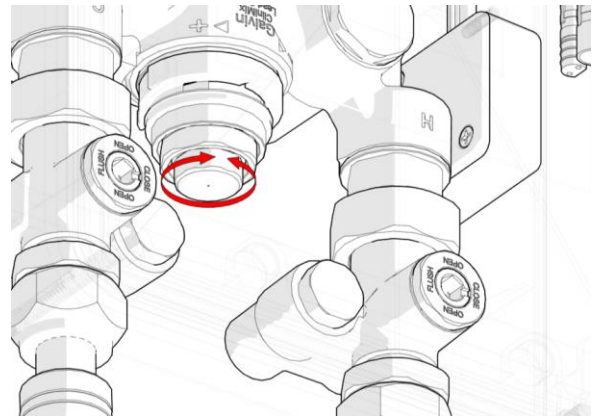
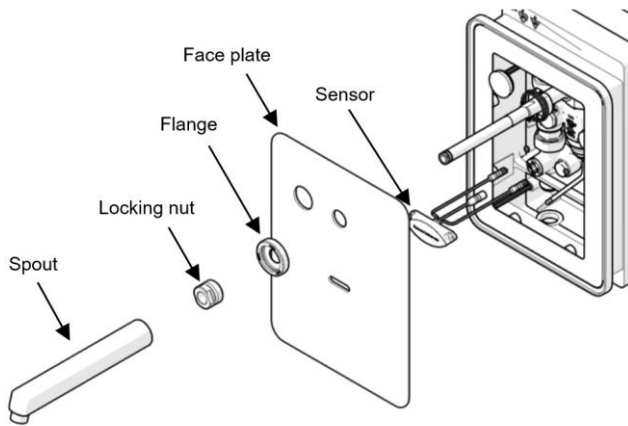

1. After checking that supply conditions are within the specified parameters (see **Error! Reference source not found.**), if the mixer malfunctions or should the test results fail to fall within the specified limits consider replacing the cartridge with a new one (see section 11.3 Important Notes On Debris). Afterwards, Follow the steps in section 10.2.2 Thermostatic Cartridge to remove and inspect cartridge.
2. Set the temperature as per step 5 in section 11.1 **MIXED WATER TEMPERATURE ADJUSTMENT**.
3. Re-commission the mixer as per commissioning procedure (See section 8.0 Commissioning). Record the mixed water temperature.

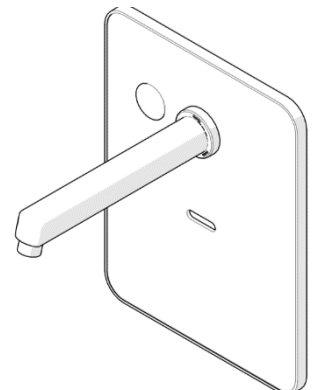

11.3 IMPORTANT NOTES ON DEBRIS

Although this product is protected by built-in filters, debris can still find its way to the thermostat housing area. This can happen during servicing for example. Remove cartridge (See section 11.2 Removal And Inspection Of Cartridge) and carry out an inspection.

11.4 MAINTENANCE CLEANING

On a regular basis the anti-splash nozzle should be inspected and cleaned if necessary. This should be done immediately before sterilising is carried out.

In areas where lime scale build-up is prevalent this will have to be removed. An inhibited proprietary scale solvent can be used such a kettle descaling solvent, but it is important to follow the manufacturer's guidelines. After descaling it is important to rinse the parts thoroughly in clean water. Clean carefully and do not use abrasive materials or scrapers.

12.0 DISINFECTION

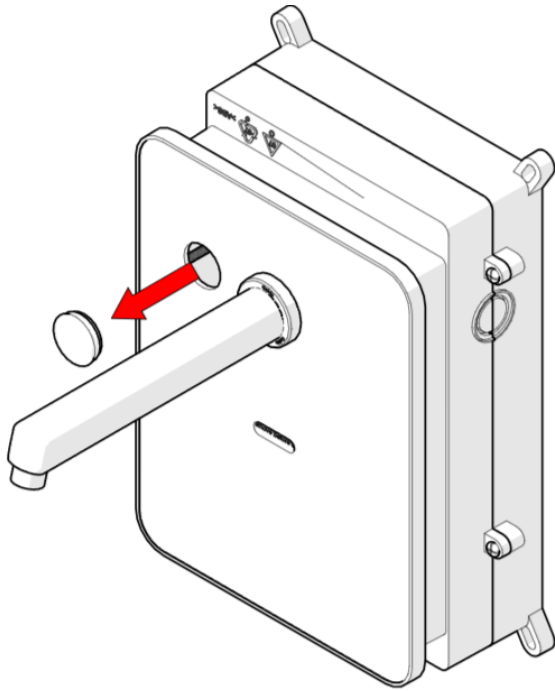

1. Remove the Disinfection Key cover

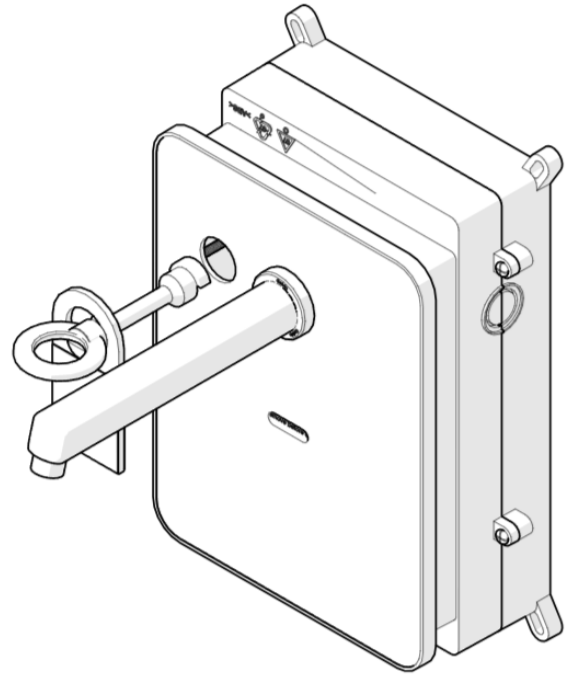

2. Hang the warning tag plate on the Disinfection Key, insert the Disinfection Key and turn it 180° (direction not important). Place the warning tag in the keys' groove. Activate "Continuous run" Function (See section 7.2 SENSOR SETTING INSTRUCTIONS).



WARNING: Spout and water temperature flowing out from spout during disinfection period might be very hot and cause scalding.

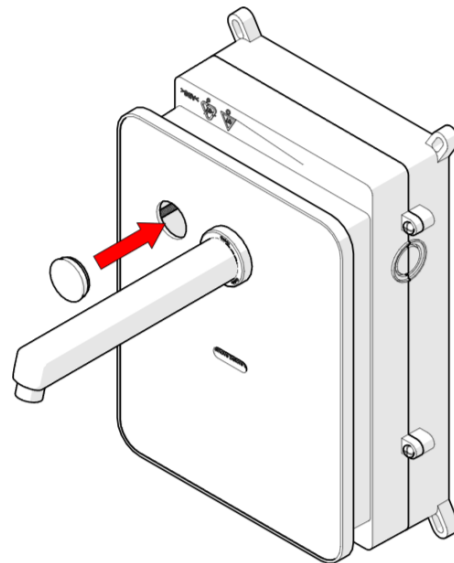
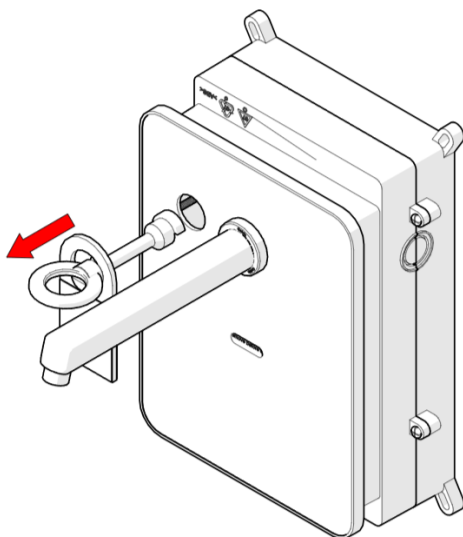

3. Turn the Disinfection Key 180° to remove it and install the key cover.

Note: A disinfection kit is available. For more information, please visit www.galvinengineering.com.au.

13.0 TROUBLESHOOTING

PROBLEM	CAUSE	RECTIFICATION
Sensor Not Responding	<ul style="list-style-type: none"> - Damaged or scratched lens - Sensor length too short - Lead damaged - No power - Waving hand too fast - Transformer faulty 	<ul style="list-style-type: none"> - Replace the sensor unit - Adjust beam to correct length. - Replace connected item. - Check power is on - Slow down the action in front of the sensor - Replace transformer
False Activation	<ul style="list-style-type: none"> - Sensor length too long - Reflection from a light source 	<ul style="list-style-type: none"> - Adjust sensor length to correct length - Re-align sensor or shield light source
The desired mixed water temperature cannot be obtained, or valve is difficult to set.	<ul style="list-style-type: none"> - Hot and cold supplies are fitted to the wrong connections - Thermostatic cartridge contains debris or is damaged - Strainers contain debris - Non-return devices are damaged 	<ul style="list-style-type: none"> - Refit the valve with Hot/Cold supplies fitted to the correct connections - Clean the Cartridge ensuring that all debris is removed, and components are not damaged. Replace if necessary - Clean strainers ensuring debris is removed - Check non-return device is not jammed. Clean it if necessary - Check for airlocks in the water supply
When the water is set at cold, the blended temperature is too hot	<ul style="list-style-type: none"> - Hot & Cold water supply connections are installed in reverse. 	<ul style="list-style-type: none"> - Refit the valve with Hot/Cold supplies fitted to the correct connections
The thermostatic mixing valve will not shut down	<ul style="list-style-type: none"> - The hot to cold mix temperature differential is not 10°C or greater - Thermostatic cartridge contains debris or is damaged - Non-return devices are damaged 	<ul style="list-style-type: none"> - Raise hot water temperature - Clean the cartridge ensuring that all debris is not jammed. Clean if necessary
Mix temperature unstable	<ul style="list-style-type: none"> - Flow rate below 6 L/min - Thermostatic cartridge contains debris or is damaged - Strainers contain debris - Non-return devices are damaged 	<ul style="list-style-type: none"> - Rectify any pressure deterioration - Clean the cartridge ensuring that all debris is removed and components are not damaged. Replace if necessary - Clean strainers ensuring debris is removed - Check non-return device is not jammed. Clean if necessary
Mix temperature changing over time	<ul style="list-style-type: none"> - Inlet conditions (pressure or temperatures) are fluctuating - Strainers contain debris 	<ul style="list-style-type: none"> - Install suitable pressure control valves to ensure inlet conditions - Clean strainers ensuring debris is removed
Either full hot or cold flowing from outlet fixture	<ul style="list-style-type: none"> - Hot/Cold water has migrated to another inlet - No flow from Hot and Cold supplies – damaged check valves 	<ul style="list-style-type: none"> - Re-set temperature to between 35-45°C as required - Replace faulty check valves
Water is not flowing from outlet	<ul style="list-style-type: none"> - Hot or cold water failure - Thermostatic cartridge contains debris or damage - Strainers contain debris 	<ul style="list-style-type: none"> - Remove aerator and clean then reinstall - Restore inlet supplies and check mix temperature - Clean the cartridge ensuring that all debris is removed and components are not damaged. Replace if necessary - Clean strainers

14.0 WARRANTY

The warranty set forth herein is given expressly and is the only warranty given by the Galvin Engineering Pty Ltd. With respect to the product, Galvin Engineering Pty Ltd makes no other warranties, express or implied. Galvin Engineering Pty. Ltd. hereby specifically disclaims all other warranties, express or implied, including but not limited to the implied warranties of merchantability and fitness for a particular purpose.

Galvin Engineering Pty Ltd products are covered under our manufacturer's warranty available for download from www.galvinengineering.com.au Galvin Engineering Pty Ltd expressly warrants that the product is free from operational defects in workmanship and materials for the warranty period as shown on the schedule in the manufacturer's warranty. During the warranty period, Galvin Engineering will replace or repair any defective products manufactured by Galvin Engineering without charge, so long as the terms of the Manufacturer's warranty are complied with.

The remedy described in the first paragraph of this warranty shall constitute the sole and exclusive remedy for breach of warranty, and Galvin Engineering Pty Ltd shall not be responsible for any incidental, special or consequential damages, including without limitation, lost profits or the cost of repairing or replacing other property which is damaged if this product does not work properly, other costs resulting from labour charges, delays, vandalism, negligence, fouling caused by foreign material, damage from adverse water conditions, chemical, electrical or any other circumstances over which Galvin Engineering has no control. This warranty shall be invalidated by any abuse, misuse, misapplication, improper installation or improper maintenance or alteration of the product.

Within Australia: **1300 514 074** Outside Australia: P: **+61 (0)8 9338 2344**

F: +61 (0)8 9338 2340

sales@galvinengineering.com.au

www.galvinengineering.com.au

ABN: 78 008 719 382

PERTH | SYDNEY | MELBOURNE | BRISBANE | ADELAIDE



Galvin Engineering Thermostatic Mixing Valve or Tempering Valve Commissioning Report and/or Maintenance Report

Note:

1. Please use a separate form for each valve.
2. The original copy of the report is to be given to the owner/occupier and retained on site for a minimum of 7 years.

Cross off appropriate box

Thermostatic Mixing Valve

Tempering Valve

Commissioning Report

Maintenance Report

Name of Establishment: _____

Address of Establishment: _____

Phone Number: _____ Date: _____ Work Order #: _____

Contact Person: _____ Make & Model of Hot Water System: _____

Temperature of Hot Water to the Valve: _____ Temperature of Cold Water to the Valve: _____

Hot Water Pressure: _____ kPa Cold Water Pressure: _____ kPa

Make of Mixing Valve: _____ Model No: _____ Size: _____

Valve Location/Building: _____

Valve Identification No: _____

Total No of Valves on the Site/Building: _____

No of Outlets Serviced by this Valve: Baths () Basins () Showers ()

Other Outlets - Details _____

Valves Installed to the requirements of:

The Valves manufacturers requirements	Yes	No
The specifications and drawings for the project	Yes	No
The Local Water Supply or Authority	Yes	No

If No, give details and actions taken:

Galvin Engineering Thermostatic Mixing Valve or Tempering Valve Commissioning Report and/or Maintenance Report

Test Results

Valve considered satisfactory for use: Yes No

If No, state the reason and action taken:

Commissioning Work

It is hereby certified that all the commissioning work has been carried out by the undersigned in accordance with the requirements of the Codes of Practice indicated prior.

Date of Valve Commissioned: _____

Name of Licensed Plumber: _____ License/Cert No: _____

License Plumbers Signature: _____

Telephone No. _____

Owner/occupiers signature: _____ Date: _____

Date of Initial Service Due: _____

Galvin Engineering Thermostatic Mixing Valve or Tempering Valve Commissioning Report

Valve Location/Building : _____

Room or Area: _____

Work Order No.: _____

Warm Water Outlet Fixture No.	*Name/Type/Size and location of Outlet Fixture (Bath, Shower, Basin, Other)	Flow rate of Design Water (LPS)		Temp of Warm Water (C)	
		One Outlet in Use	**All Req'd Outlets in Use	One Outlet in Use	**All Req'd Outlets in Use
1.					
2.					
3.					
4.					
5.					
6.					
7.					
8.					
9.					
10.					
11.					

*Give details of brand and model designation.

** Commensurate with the design flow rate for the mixing valve.

Note: An accurate digital thermometer is necessary for the temperature measurements

Prescribed temperature range for warm water _____ C to _____ C

Thermal shutdown at both minimum and maximum design flow rates

(Passed/Failed) Yes No Name of Plumber: _____

License/Cert No. _____

Licensee's Signature: _____ Date: _____ Telephone Number: _____

Galvin Engineering Thermostatic Mixing Valve or Tempering Valve Commissioning/Maintenance Report

The following information is to be provided by the site manager/owner/occupier.

Valve size and installation recommended by : _____

Valves supplied by: _____

Date of Installation: _____ Drawing No. _____

Service Manual on Site: Yes No

Commissioning Tests for new installation or valve replacement. Yes

This set of testing procedures and report received and witnessed by (Print Name): _____

Temperature setting at completion of commissioning _____ C

Position: _____ Signature: _____ Date: _____

Maintenance Tests. Yes

Date of Previous Service: _____

Previous Service carried out by: _____

Reason for Maintenance Tests: _____

This Test and report Witnessed by: _____

The valve has been operating/performing satisfactorily for the previous 12 months: Yes No

Comment on monthly Temperature Tests carried out by the owner: _____

Temperature setting at time of completion: _____ C

Current Report received and witnessed by:

Name: _____

Position: _____

Signature: _____ Date: _____